

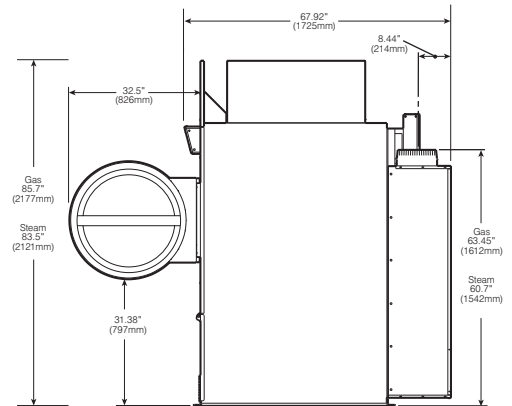

# CG115-25

PRO-SERIES II DRYING TUMBLER

Capacity <i>lbs</i>	up to 125
Cylinder Diameter <i>inch (mm)</i>	44 (1118)
Cylinder Depth <i>inch (mm)</i>	41 (1041)
Cylinder Volume <i>cu ft (dm<sup>3</sup>)</i>	36.1 (1.02)
Net Weight <i>lbs (kg)</i>	
Gas/Electric	1275 (578)
Steam	1375 (624)
Crated Weight <i>lbs (kg)</i>	
Gas/Electric	1338 (607)
Steam	1446 (656)
Machine Width <i>inch (mm)</i>	46.38 (1178)
Machine Depth <i>inch (mm)</i>	67.92 (1725)
Machine Height <i>inch (mm)</i>	
Gas	85.7 (2177)
Steam	85.58 (2147)
Door Opening <i>inch (mm)</i>	26.89 (683)
Floor to Door <i>inch (mm)</i>	31.38 (797)
Shipping Dimensions <i>inch (mm)</i> (WxDxH)	48.5 x 71.5 x 90 (1232 x 1816 x 2286)
Reversing Motor Power <i>Hp (kW)</i>	
Cylinder	3/4 (0.56)
Fan	1 (0.75)
Exhaust Diameter <i>inch (mm)</i>	10 (254)
Exhaust Air Flow <i>cfm (l/s)</i>	1600 (755)
Electric Heating <i>kW</i>	60
Gas Connection <i>inch (mm)</i>	1 NPT (25.4)
Gas Heating <i>BTU/h (Kcal/h)</i>	270,000 (68,040)
Steam Connection <i>inch (mm)</i>	3/4 NPT (19)
Condensate Outlet Connection <i>inch (mm)</i>	3/4 NPT (19)
Steam Heating <i>BTU/h (kW)</i> at 100 PSI (6.9 bar)	405,000 (118.7)
BHP Consumption <i>BHP</i> at 100 PSI (6.9 bar)	11.7
Available Voltages/Wire Conductor/Amp (Rev Amp) Gas/Steam	200-208/240/60/3, 3W + G, (7.7) 440/60/3, 3W + G, (3.8) 460-480/60/3, 3W + G, (3.9)
Electric	240/60/3, 3W + G, (152) 480/60/3, 3W + G, (76.1)



SIDE VIEW

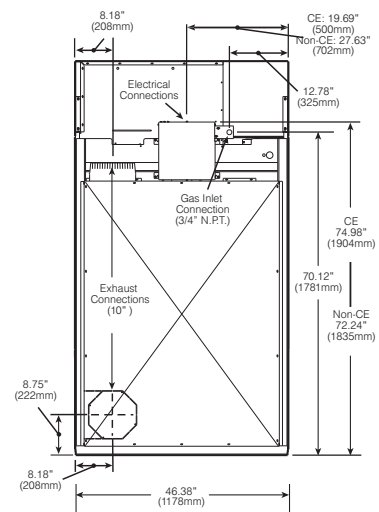

Gas Models and Electric Models

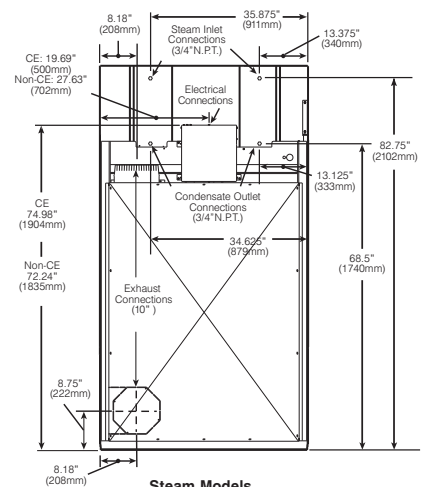

Steam Models

\* Specifications subject to change without notice or obligation. Call Continental Girbau Inc for dimensions not shown or for clarification.