

C6-MU

EXPRESSDRY GEAR DRYERS

Maximum Number of Gear Sets	6
Crated Weight <i>lbs (kg)</i>	420 (191)
Machine Width <i>inch (mm)</i>	120.5 (3061)
Machine Depth <i>inch (mm)</i>	30 (762)
Machine Height <i>inch (mm)</i>	80 (2032)
Shipping Dimensions <i>inch (mm)</i> (WxDxH)	122 x 30 x 26 (3099 x 762 x 660)
Motor Power <i>HP</i>	1
Motor Speed <i>rpm</i>	3450
Air Flow <i>cfm</i>	800
Available Voltages	120/60/1 220/60/1 (optional)
Amps	7.8
Fan Diameter <i>inch (mm)</i>	10.6 (269)
Fan Wheel Bore	5/8
Thermal Protection	auto
Timer Interval Selections	2, 4, 8 or 12 hours
Number of Drying Ports	18
dB Reference <i>machine only</i>	between 78 and 82

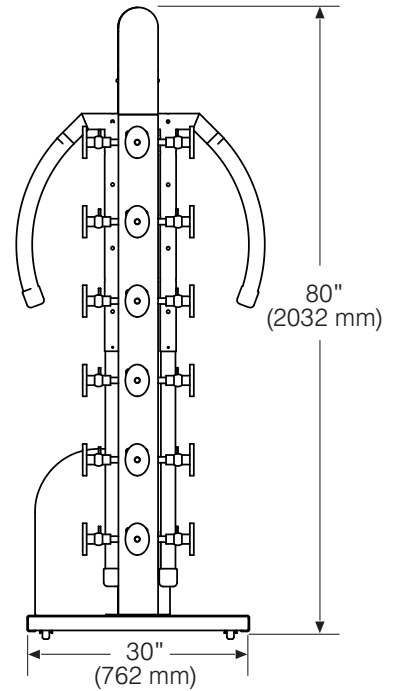

* Product design and specifications are subject to change without notice. For the most current and complete technical specifications, architectural line drawings and warranty information, please visit our website at www.cgilaundry.com.

